

G 250 / G 500 / G 1000



G Series



G 250/500



G 1000

Produttori automatici di ghiaccio a scaglie granulari.

Struttura interna ed esterna interamente in acciaio inox 18/8. Ghiaccio a granuli compatti, per i diversi impieghi in ristoranti, pescherie, self-service ed industrie. Modelli modulari, senza deposito interno di raccolta ghiaccio, occorre abbinarli ad un contenitore di raccolta BIN (disponibile in diversi modelli).

Automatic granular ice flakers.

Inner and outer structure of stainless steel 18/8. Compact granular ice for various different uses in restaurant, fish-shops, self-service and industries. Modular models, without internal ice storage bin. Must be combined with a collection BIN (different models available).

Machines à paillettes.

Structure intérieur et extérieur en acier inox 18/8. Glace en paillettes granulées pour usages dans les restaurants, les poissonneries, les self-services et l'industries. Modèles modulaires: sans réserve intégrée de glaçons il faut l' assortir d' un réserve BIN (disponibles dans divers modèles).



G Series

G 250-500 / G 1000

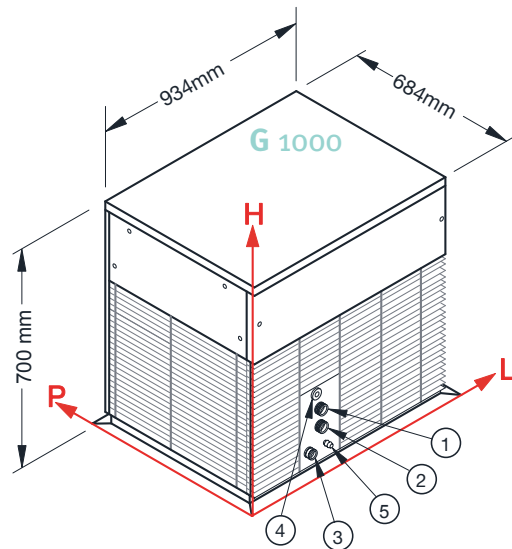
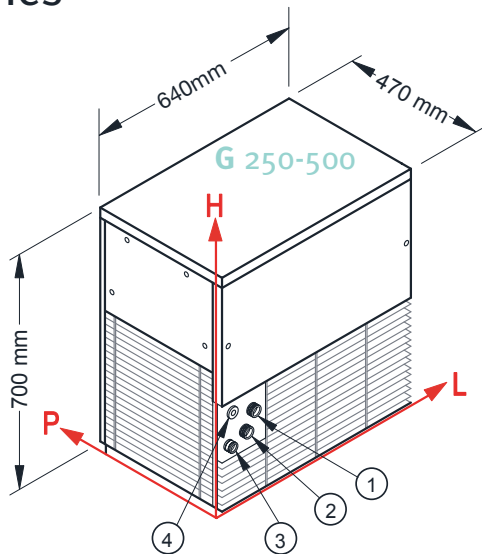

	1			2*			3			4			5*		
	L	H	Ø	L	H	Ø	L	H	Ø	L	H	Ø	L	H	Ø
G 250-500	116	282	3/4"	84	238	3/4"	34	228	24mm	58	292	-	-	-	-
G 1000	372	187	3/4"	372	120	3/4"	337	60	24mm	358	257	-	382	60	12mm

* Only for water cooling system

	Produzione in 24 h, sino a: Production in 24 h till: Production en 24 h jusqu'à:	Raffreddamento Cooling System Condenseur	Refrigerante Refrigerant Fluide refrigerant	BIN utilizzabile Usable BIN Réserve utilisable	Voltaggio Standard Standard Voltage Tension standard	Potenza assorbita Input power Puissance absorbée	Consumo acqua (l/kg) Water consumption (l/kg) Consommation d'eau (l/kg)	Dimensioni (LxPxH) Sizes (WxDxH) Dimension (LXPXH)	Dimensioni con imballo (LxPxH) Sizes with packing (WxDxH) Dimension (avec emballage) (LXPXH)	Peso netto/lordo Weight net/gross Poids net/brut
G 250					V/Hz	W				
G 500	250 Kg	A W	R404A	BIN 240PE - G250/500 BIN T120 - G250/500 BIN T280 - G250/500 Double Roller Bin - G250/500 ROLLER BIN	220-240/1/50	1050 W	A 1 W 5,2	mm 640x470x700	mm 695x540x940	82/93 Kg
G 1000	500 Kg	A W	R404A	BIN 240PE - G250/500 BIN T120 - G250/500 BIN T280 - G250/500 Double Roller Bin - G250/500 ROLLER BIN Double Roller Bin 500	220-240/1/50	1700 W	A 1 W 5,3	mm 640x470x700	mm 695x540x940	104/113 Kg
	1000 Kg	A W	R404A	Double Roller Bin 500	400/3N/50	3200 W	A 1 W 5,3	mm 934x684x700	mm 1000x770x920	172/195 Kg

Finitura: acciaio inox 18/8, scotch brite - Finishing: 18/8 stainless steel, scotch brite - Carrosserie: inox 18/8, scotch brite.



Condizioni
Conditions
Conditions



V / Hz



Minimum	+10 °C	+3 °C	-10%	1bar (14psi)
Maximum	+43 °C	+32 °C	+10%	6bar (84psi)



www.bremaice.it
info@bremaice.it

VIA DELL'INDUSTRIA, 10

20020 VILLA CORTESE (MI), ITALY

TEL. +39 0331 434811
FAX +39 0331 433833



OHSAS 18001:1999
Cert. N. 9192,BREZ

+21°C
+15°C
Watt + 43°C (230/1/50)